

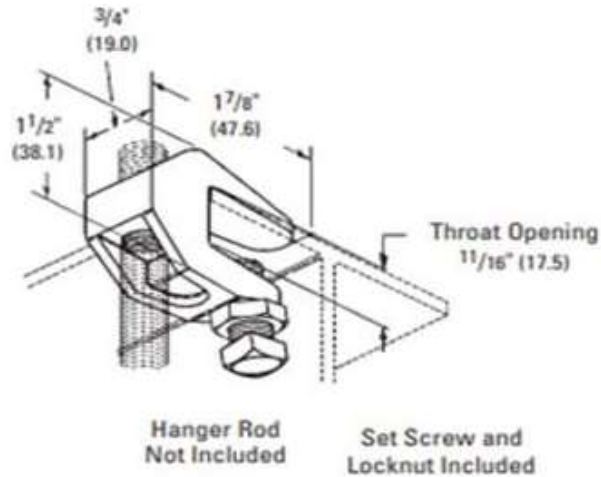

relationships **FORGED**  
solutions **CAST**

# BEAM CLAMP



## Application:

This clamp can be used with bar joist construction. It can be attached to top or bottom sections of beam.

## How to size:

Size of clamp is determined by size of rod to be used.

## Size Range:

3/8" & 1/2"

## Material:

Malleable Iron & Steel

## Finish:

Plain & Electro-Galvanized

## Approval:

FM approval & UL listed

## Features:

- They may be attached to horizontal flanges of structural members in either the top beam or bottom beam positions.
- Secured in place by a cup-pointed Set Screw tightened against the flange. A Jam Nut is provided for tightening the Set Screw against the Body Casting.
- Thru tapping of the body casting permits extended adjustment of the threaded rod.

**To order or for further details, please call (800) 848-6884 or email: [orders@uvintl.com](mailto:orders@uvintl.com)**

## Headquarter

**U.V International LLC**  
360 Mount Kemble Ave. Suite 2000  
Morristown, NJ 07960  
**Phone:** 973 775-1660  
**Fax:** 973 775-1680

## Distribution Centers

Hueytown, AL; Fontana, CA; West Sacramento,  
CA; Atlanta, GA; Hagerstown, MD;  
Dallas, TX; Houston, TX