



relationships **FORGED**
solutions **CAST**

Resilient Wedge NRS Gate Valve - Mechanical Joint x Mechanical Joint End

Ref: NRSMJMJ1024

Technical Features

- Mechanical Joint: ANSI/ AWWA 110 or ANSI/ AWWA C153
- Size: 3 - 12"
- Dimensions: ANSI/ AWWA C515 Standard
- Certification: UL, FM ,NSF61
- Maximum Working Pressure: 300 PSI (Conforms to UL 262, FM 1120/1130)
- Maximum Working Temperature: 80 Degree Celcius
- Coating Details: Epoxy Coated Interior / Electrostatic Spray Exterior

Dimensions

Size		Dimensions (mm)		
Inch	mm	L	D	H
3"	80	203	195	322
4"	100	229	232	342
6"	150	267	282	448
8"	200	292	340	534
10"	250	330	399	635
12"	300	356	456	720

Material List

Sr. No.	Name	Material
1	Flat Washer	Steel 1045 or Stainless Steel 304
2	Hexagon Socket Screw	Steel 1045 or Stainless Steel 304
3	Sealing Ring	EPDM
4	O- Ring	EPDM
5	Sealing Ring	EPDM
6	O-Ring	EPDM
7	Bonnet	Ductile Iron
8	Stem	Stainless Steel 304 or Steel 1045
9	Disc	Ductile Iron+ EPDM
10	Body	Ductile Iron
11	Sealing Ring	EPDM
12	Retaining Ring	C95400
13	Gland	Ductile Iron
14	Post Flange	Ductile Iron
15	Wrench Nut	Ductile Iron
16	Bolt	Stainless Steel 304 or Steel 1045
17	Washer	Stainless Steel 304 or Steel 1045
18	Hexagon socket Screw	Stainless Steel 304 or Steel 1045
19	Stem Nut	CF8 or C95400

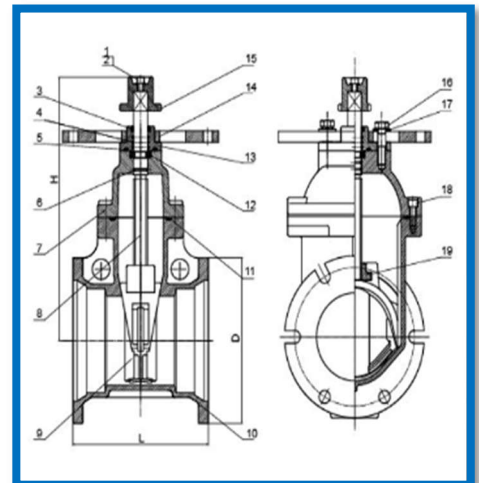

To order or for further details, please call (800) 848-6884 or email:
orders@uvintl.com

Headquarters

360 Mount Kemble Ave. Suite 2000
Morristown, NJ 07960
Ph: (973) 775-166; Fax: (973) 775-1680
Email: uvnj@uvintl.com

Distribution Centers:

Atlanta, GA; Hagerstown, MD.
Houston, TX; Dallas, TX; Elk Grove,
CA; Orlando, FL; Fontana, CA;
Kent, WA; Saint Paul, MN;
Hueytown, AL